

Professional Supplier of Shock Absorbers



E-mail | sale@yichen-zt.com

Phone / WeChat | + 8615031762785

WhatsApp | + 8619358001974

Address | Dalutun Village, Siying Township, Botou City,
Cangzhou City, Hebei Province.



Shock absorber Professional supplier

Provide customers with damping spring shock absorbers, hanging spring shock absorbers, rubber shock absorbers and other types of shock absorbers, is the key projects in 31 provinces, municipalities and autonomous regions of the country's various types of mechanical equipment on the vibration isolation and noise reduction of the professional suppliers.

Hebei Yichen Shock Absorber Manufacturing Co., Ltd.



CONTENTS

02 About

03 Cooperation Process

05 Application Cases

06 Production equipment

07 Product

Suspended spring shock absorber		07
Damping spring shock absorber		11
Rubber shock absorber		21
Air shock absorber		29
Pipe shock absorber		31
Acoustic decoration shock absorber		34
Suspended spring shock absorber		35

Professional Supplier of Shock Absorbers.

Hebei Yichen Shock Absorber Manufacturing Co., Ltd. is located in Botou, China, and is a company dedicated to the shock absorption industry, focusing on the research, design, and manufacturing of various types of shock absorbers. With over 20 years of rich experience, we have deep professional knowledge and technical strength in the field of shock absorption, providing customers with comprehensive solutions.

Product Range

We specialize in the production of various types of shock absorbers, including damping springs, hanging springs, rubber shock absorbers, etc., which are widely used in industrial equipment and pipelines for shock absorption and noise reduction.

Customized services

We provide non-standard design modifications based on customer needs, and provide professional customized shock absorption solutions for large industrial manufacturers.

Team service

We have a highly skilled team to provide customers with professional answers and technical guidance. We are always customer-centric and provide high-quality service and support.

Production advantages

We have advanced equipment and technology and use high-quality raw materials to ensure product quality and performance.

International experience

Our products are widely used in key projects across the country; our international market business network covers many countries in Asia, the Middle East and Europe, and we have established solid cooperative relationships with customers. The products have passed international certification and provide customers with efficient and reliable shock absorption solutions.



02 | Solution Development and Confirmation

Solution Design and Optimization:

Our engineering team designs shock absorber solutions to meet customer requirements, considering structural design, materials, and processes.

Solution Submission and Discussion:

We present solutions, technical details, and quotes to customers for review and feedback. We refine solutions based on their input until agreement is reached.



01 | Demand Confirmation and Communication

Requirement Collection and Analysis:

Our sales team gathers detailed requirements and technical parameters from customers regarding custom shock absorbers, including application scenarios, vibration parameters, and environmental specifications.

Technical Consultation and Suggestions:

Our experienced technical team analyzes customer-provided information, offers tailored technical advice, and collaborates on potential solutions.

03 | Production and Delivery

Production Preparation:

We commence material procurement, production planning, and equipment readiness after solution confirmation.

Production Manufacturing:

Custom g to the finalized solution and technical specifications, with rigorous quality control measures in place.

Quality Inspection:

Thorough inspections are conducted throughout production, encompassing appearance, dimensions, and performance.

Product Delivery:

Products are packaged as per customer specifications and arranged for prompt delivery after production.

05 | Long-term Cooperation and Continuous Optimization

Cooperation Enhancement:

We prioritize long-term partnerships and strive to consistently deliver superior products and services tailored to customer needs. We continuously refine our offerings based on market insights and technological advancements to meet evolving customer requirements.

04 | After-sales Service and Feedback

After-sales Support:

We offer comprehensive services, including technical support, maintenance, and warranty. We conduct regular customer satisfaction surveys to promptly address feedback and resolve issues.

Technical Training:

We provide customized product usage and maintenance training to ensure customers can properly utilize and care for their shock absorbers.



Water pump

Air energy



Fan/Wind turbine



Transformer

Exhaust fan



ZD type damping spring shock absorber finished product



Blue JA type adjustable height spring shock absorber finished product



Conventional size JA type adjustable height spring shock absorber finished product



Suspension/damping spring shock absorbers shipped



Customized water pump shock absorber pedestal shipped



Assembly of ZD type damping spring shock absorber



Special-shaped shock absorbers can be customized according to customer requirements!



DH type hanging spring shock absorber



Model	Load(Kg)	Outer diameter	Manager	Screws/Eyes
DH-1	10-20	40	87	M8
DH-2	20-30	40	100	M8
DH-3	30-50	47	100	M10
DH-4	50-80	60	130	M10
DH-5	80-120	60	130	M12
DH-6	120-160	76	160	M12
DH-7	160-200	76	160	M14
DH-8	200-240	76	165	M14
DH-9	240-300	76	170	M14

Note: Dimensions are measured manually and there may be errors. The actual size shall prevail.

Product Description

In industries such as construction engineering, a lot of equipment or pipes need to be hoisted, such as air conditioners, fan coil units, etc. There are many cases where the vibrations generated by the equipment affect the environment, or external vibrations affect the equipment. DH hanging spring shock absorbers can significantly improve noise and vibration problems in human living spaces. They can also improve the operating conditions of equipment, improve use effects, and extend service life.

Applicable equipment: air conditioners, fresh air fans, fan coil units, fans and precision instruments.
Load range: 3-1500Kg



Installation diagram



Support customization of special-shaped sizes and large loads.



HV type hanging spring shock absorber

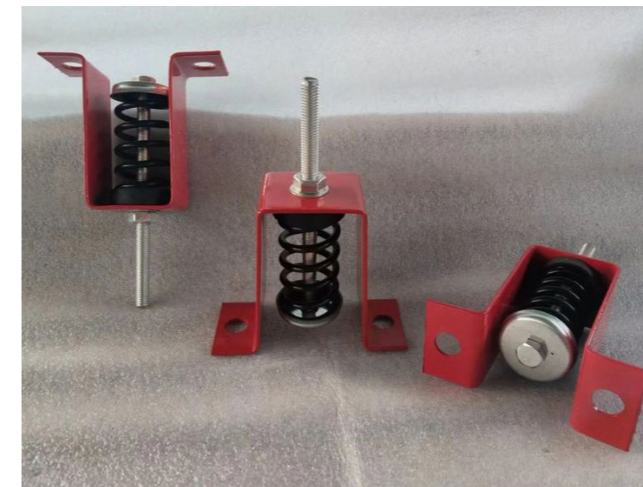

In order to meet the needs of different users, our company designs and manufactures HV type hanger shock absorbers on the basis of producing a variety of hanging shock absorbers. This product is composed of shock absorbing springs, rubber composite pads, damping, etc. of prestressed hanger shock absorbers. The range of applications is very wide.

Applicable equipment: Hoisting, isolation and noise reduction of fans, pipelines, and power equipment. It is also used in the hoisting of precision instruments, etc.
Load range: 3-1500kg

Product Description

Model	Load range (kg)	Boom	Dimensions							
			W2	W1	W3	L1	L2	H	Hole spacing (mm)	Wall thickness (mm)
HV-1	10-20	M8	100	47	28	61	105	40	78	3
HV-2	20-30	M8	115	57	29	1	125	44	94	3
HV-3	30-50	M10	120	62	30	100	155	50	96	3
HV-4	50-80	M10	131	67	34	1158	155	55	105	3
HV-5	80-120	M12	129	64	35	126	167	60	102	3
HV-6	120-160	M12	148	75	37	141	182	66	121	3
HV-7	160-200	M14	168	86	40	143	190	70	138	4
HV-8	200-240	M14	168	86	40	143	190	70	138	4
HV-9	240-300	M14	168	86	40	143	190	70	138	4
HV-10	300-450	M16	180	95	40	165	210	80	147	4
HV-11	450-650	M16	180	95	40	165	210	80	147	4
HV-12	650-1000	M16	180	95	40	165	210	80	147	4
HV-13	1000-1500	M20	180	95	40	165	210	80	147	5

Note: Dimensions are measured manually and there may be errors. The actual size shall prevail.

Product Structure

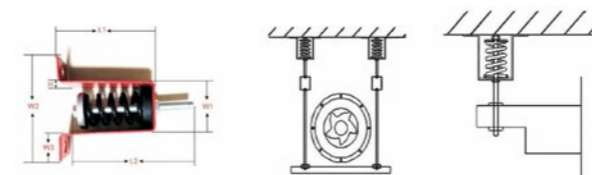

Installation diagram



Support customization of special-shaped sizes and large loads.



XHS lifting ring hook type hanging spring shock absorber

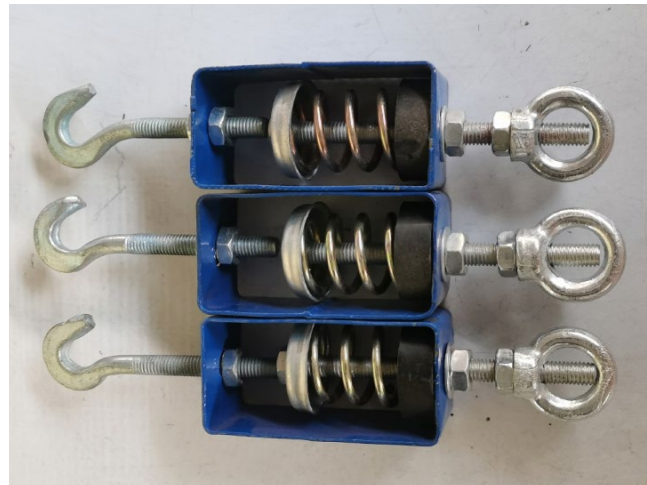

XHS type hanging spring shock absorbers are widely used in large and small equipment and pipelines. They are the first choice of spring shock absorbers for hoisting equipment. This product has large damping, low self-oscillation frequency, easy installation, and obvious effect on eliminating solid sound transmission. It is suitable for hanging installation in various large and small equipment departments and pipeline systems.

Applicable equipment: ceiling-mounted air conditioners, axial flow fans, fresh air fans, pipelines and other lifting equipment.

Load range: 3-1500kg

Product Description

Model	Load range (kg)	Boom	Dimensions					
			L1	L2	W1	W2	H	Wall thickness (mm)
XHS-0	3-10	M8	80	123	40	40	34	1
XHS-1	10-20	M8	80	126	60	60	32	1
XHS-2	20-30	M8	113	153	55	65	45	3
XHS-3	30-50	M10	123	184	57	63	49	3
XHS-4	50-80	M10	131	184	62	72	54	3
XHS-5	80-120	M12	140	191	66	76	60	3
XHS-6	120-160	M12	159	223	72	79	65	3
XHS-7	160-200	M14	182	242	86	93	70	4
XHS-8	200-240	M14	182	242	86	93	70	4
XHS-9	240-320	M14	182	242	86	93	70	4
XHS-10	320-450	M16	182	242	86	93	70	4
XHS-11	450-600	M16	182	242	86	93	70	4
XHS-12	600-1000	M20	203	265	94	112	81	4
XHS-13	1000-1500	M20	203	265	94	112	81	4

Note: Dimensions are measured manually and there may be errors. The actual size shall prevail.

Product Structure

Installation diagram



Support customization of special-shaped sizes and large loads.



XHS type hanging spring shock absorber



XHS type hanging spring shock absorbers are widely used in large and small equipment and pipelines. They are the first choice of spring shock absorbers for hoisting equipment. This product has large damping, low self-oscillation frequency, easy installation, and obvious effect on eliminating solid sound transmission. It is suitable for hanging installation in various large and small equipment departments and pipeline systems.

Applicable equipment: ceiling-mounted air conditioners, axial flow fans, fresh air fans, pipelines and other lifting equipment.

Load range: 3-1500kg

Product Description

Model	Load range (kg)	Boom	Dimensions					
			L1	L2	W1	W2	H	Wall thickness (mm)
XHS-0	3-10	M8	80	123	40	40	34	1
XHS-1	10-20	M8	80	126	60	60	32	1
XHS-2	20-30	M8	113	153	55	65	45	3
XHS-3	30-50	M10	123	184	57	63	49	3
XHS-4	50-80	M10	131	184	62	72	54	3
XHS-5	80-120	M12	140	191	66	76	60	3
XHS-6	120-160	M12	159	223	72	79	65	3
XHS-7	160-200	M14	182	242	86	93	70	4
XHS-8	200-240	M14	182	242	86	93	70	4
XHS-9	240-320	M14	182	242	86	93	70	4
XHS-10	320-450	M16	182	242	86	93	70	4
XHS-11	450-600	M16	182	242	86	93	70	4
XHS-12	600-1000	M20	203	265	94	112	81	4
XHS-13	1000-1500	M20	203	265	94	112	81	4

Note: Dimensions are measured manually and there may be errors. The actual size shall prevail.

Product Structure

Installation diagram



Support customization of special-shaped sizes and large loads.



JA type damping spring shock absorber



Model	Load (kg)	Spring (individual)	Long (mm)	Width (mm)	High (mm)	Mounting screws (M)	Hole spacing (mm)	Plate thickness (mm)
JA-1-45	30-50	1	130	60	135	M12	90	5
JA-1-80	50-80	1	130	60	135	M12	90	5
JA-1-100	80-100	1	130	60	135	M12	100	5
JA-1-150	100-150	1	150	60	150	M12	110	5
JA-1-200	150-200	1	150	60	150	M12	110	5
JA-1-250	200-250	1	160	80	150	M14	120	6
JA-1-300	250-300	1	160	80	150	M14	120	6
JA-1-450	300-450	1	180	100	180	M14	150	8
JA-1-600	450-600	1	180	100	180	M141	150	8
JA-1-800	600-800	1	180	100	180	M16	150	8
JA-4-600	450-600	4	260	120	170	M14	230	8
JA-4-800	600-800	4	260	120	170	M16	230	8
JA-4-1000	800-1000	4	260	140	170	M16	230	8
JA-4-1200	1000-1200	4	260	140	170	M16	230	8
JA-4-1600	1200-1600	4	300	180	210	M18	270	10
JA-4-2400	1600-2400	4	300	180	210	M20	270	10
JA-4-3500	2400-3500	4	300	180	215	M20	270	12
JA-4-5000	3500-5000	4	320	180	215	M22	290	14
JA-6-5000	3500-5000	6	420	200	230	M24	390	14
JA-6-7000	5000-7000	6	420	200	230	M24	390	8

Support large load and large size customization
 Note: Dimensions are measured manually and there may be errors. The actual size shall prevail.

Product Description

XHS type hanging spring shock absorbers are widely used in large and small equipment and pipelines. They are the first choice of spring shock absorbers for hoisting equipment. This product has large damping, low self-oscillation frequency, easy installation, and obvious effect on eliminating solid sound transmission. It is suitable for hanging installation in various large and small equipment departments and pipeline systems.

Applicable equipment: ceiling-mounted air conditioners, axial flow fans, fresh air fans, pipelines and other lifting equipment.

Load range: 3-1500kg

Product Structure

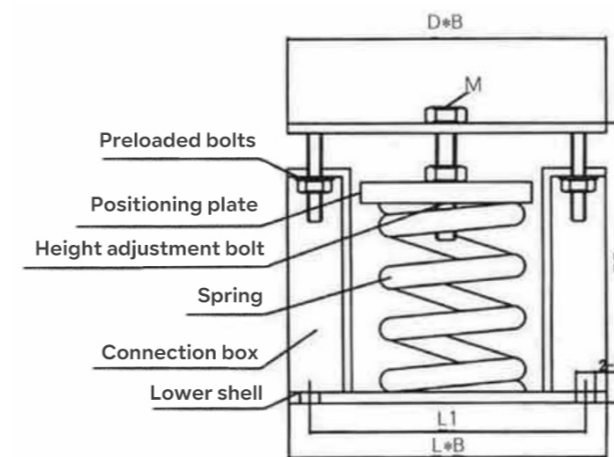

Installation Diagram



YDS type damping spring shock absorber



This product has a wide load range, long working life, and is safe and reliable to use. There are non-slip rubber pads on the surface of the YDS type upper and lower seats. For equipment with low disturbance and low stress, the YDS type shock absorber can be placed directly under the equipment shock absorption pedestal without fixing: the YDS1 type upper seat is equipped with bolts to fix the equipment. YDS2 type upper and lower seats are respectively equipped with bolt and foundation bolt holes, which can be fixed downward. Users can choose according to different needs and occasions.

The applicable working temperature of YDS series products is -40C-110C, the natural frequency within the normal working load range: 2HZ-5HZ, and the damping ratio: 0.045-0065

Applicable equipment: shock absorption of fans, water pumps, compressors and other equipment and supporting installation of various vibration reduction pedestals
Load range: 5-1500Kg

Product Description

Model	Load range (kg)	Dimensions						Bottom hole (Φ)
		H	L	L1	B	D	M	
YDS-1	10-20	75	90	70	55	40	10	8.5
YDS-2	20-30	75	90	70	55	40	10	8.5
YDS-3	30-50	75	90	70	55	40	10	8.5
YDS-4	50-80	80	105	85	75	45	12	10.5
YDS-5	80-120	90	105	85	75	50	12	10.5
YDS-6	120-160	100	105	85	75	55	12	10.5
YDS-7	160-200	110	155	130	90	60	14	12.5
YDS-8	200-240	120	155	130	90	65	14	12.5
YDS-9	240-300	130	180	140	100	70	16	14.5
YDS-10	300-450	145	180	140	100	75	16	14.5

Note: Dimensions are measured manually and there may be errors. The actual size shall prevail.

Product Structure

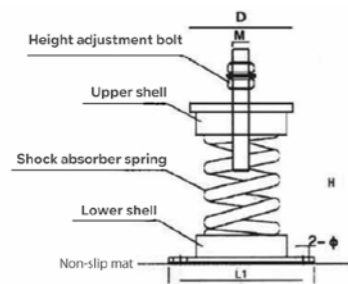
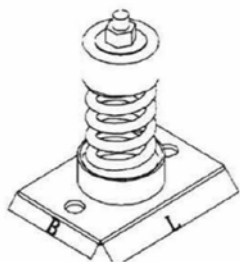

Installation diagram



Support customization of special-shaped sizes and large loads.



ZTE type damping spring shock absorber



The damping spring shock absorber is made of ordinary cast iron or ball-milled cast iron with hot-dip galvanizing treatment, featuring excellent weather resistance. With a special structural design, it can adjust height as needed, and is easy to install with anti-slip rubber cushions at both the top and bottom. Light in weight yet sturdy, it is suitable for various mechanical shock absorption applications. The springs, treated through various processes, have deflections of 20mm and 40mm, effectively reducing mechanical vibrations. Before installation, confirm the correct model specifications and compression range of 10-25mm. After placing the shock

absorber correctly, remove the fixed bolts, install the equipment's fixed base onto the shock absorber, and secure it. Adjust the height to make the equipment level, then connect the pipelines or machinery nearby. If additional loads are added, such as suspended pipelines, an XDD-type pipeline shock absorber should be installed to ensure sufficient load capacity.

Applicable equipment: chillers, cooling water towers, floor fans or floor air conditioning boxes, etc.
Load range: 5-1500Kg

Product Description

Model	Load (kg)	High (mm)	Long base (mm)	Base width (mm)	Base hole distance (mm)	Top mounting screws (M)
ZTE-1	5-20	125	135	70	115	10
ZTE-2	20-30	125	135	70	115	10
ZTE-3	30-50	125	135	70	115	10
ZTE-4	50-80	130	135	70	115	10
ZTE-5	80-120	143	155	76	140	12
ZTE-6	120-180	143	155	76	140	12
ZTE-7	180-250	143	155	76	140	12
ZTE-8	250-300	180	225	95	200	14
ZTE-9	300-500	180	225	95	200	14
ZTE-10	500-700	180	225	95	200	16
ZTE-11	700-1000	180	225	95	200	16
ZTE-12	1000-1500	180	225	95	200	16

Note: Dimensions are measured manually and there may be errors. The actual size shall prevail.

Installation diagram



Support customization of special-shaped sizes and large loads.



ZGT type damping spring shock absorber (closed)



Product Description

ZGT type damping spring shock absorber (enclosed type) is a product designed based on the low speed and large disturbance force of large-scale foreign chillers installed with unbalanced power equipment. This product has the advantages of great installation flexibility, good stability, low natural frequency, and significant vibration isolation effect. The ZGT damping spring shock absorber (closed type) is composed of multiple combined spring groups, upper and lower steel plates, and rubber anti-slip pads pasted on the outer surfaces of the steel plates. ZGT type damping spring shock absorber (closed type) is divided into ZGT-D type which is open type. ZGT-D2 type is closed type and has various specifications, or it can be designed and manufactured according to the special needs of users.

Under rated load, the corresponding vertical self-seismic frequency is 2.3Hz-4.9Hz, and the damping ratio is 0.02-0.06. It is an ideal product for active seismic isolation.

ZGT type damping spring shock absorber (enclosed type) can be placed directly under the equipment when installed. If the disturbance force of the power equipment is large, adjust the center of gravity first and fix the shock absorber base fixing holes on the foundation with bolts. ZGT type damping spring shock absorber (closed type) corresponds to the vertical natural frequency of 2.3Hz-4.9Hz under rated load, the damping ratio is 0.02-0.06, and the deflection can reach 75mm. It is an ideal product for active isolation.

Applicable equipment: chillers, diesel generators, punch presses, compressors, refrigeration units, transformers and other large equipment
Load range: 150-7000Kg

Model	Load (kg)	Number of spring groups	On board length*width (mm)	Lower board length*width (mm)	High ±10% (mm)	Install screws (M)	Hole spacing ±10%	Plate thickness (mm)
ZGT-150	50-150	4	100*100	150*150	90	12	130	5
ZGT-280	150-280	4	120*120	180*180	95	12	160	5
ZGT-450	280-450	4	130*130*	190*190	105	12	170	5
ZGT-600	450-600	4	140*140	200*200	110	12	180	5
ZGT-750	600-750	4	160*160	220*220	110	12	200	6
ZGT-900	750-900	4	160*160	220*220	125	12	200	8
ZGT-1200	900-1200	4	180*180	240*240	125	14	220	8
ZGT-1800	1200-1800	4	190*190	240*240	145	14	220	10
ZGT-2500	1800-2500	4	200*200	250*250	145	14	230	10
ZGT-3500	2500-3500	4	200*200	280*280	160	14	260	12
ZGT-5000	3500-5000	4	200*200	280*280	165	14	260	14
ZGT-7000	5000-7000	6	200*260	330*260	165	14	310/240	16

Special-shaped shock absorbers can be customized according to customer needs
Note: Dimensions are measured manually and there may be errors. The actual size shall prevail.

Product Structure

Installation diagram

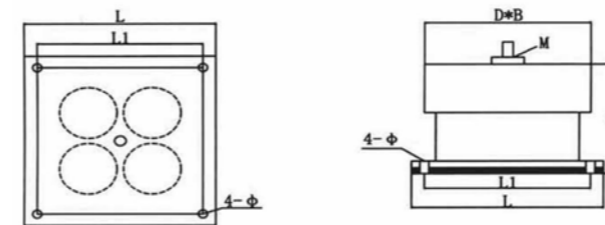

ZGT type damping spring shock absorber (open)



Product Description

The ZGT type low-frequency damping steel spring shock absorber is composed of multiple combined spring groups, upper and lower steel plates, and rubber anti-slip pads pasted on the outer surfaces of the steel plates. ZGT type low-frequency damping steel spring shock absorber is a product designed by our factory based on the unbalanced installation of large-scale chillers abroad, low speed of power equipment and large disturbance force. This product has great installation flexibility, good stability and low natural frequency., remarkable isolation effect and other advantages. It can be placed directly under the equipment during installation. If the power equipment has a large disturbance, adjust the center of gravity first, and fix the shock absorber base fixing holes on the foundation with bolts. The ZGT type low-frequency damping steel spring shock absorber corresponds to a vertical self-seismic frequency of 2.3HZ-4.9Hz under rated load, a damping ratio of 0.02-0.06, and a deflection of up to 75mm. It is an ideal product for active isolation.

Applicable equipment: chillers, diesel generator units, compressors, refrigeration units, air conditioning units and other large equipment.
Load range: 30-10000Kg



Product Structure

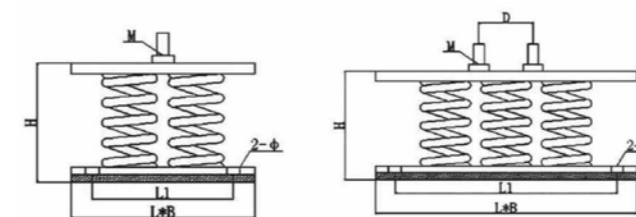

Installation diagram



Model	Load (kg)	Number of spring groups	Length (mm)	Width (mm)	High ±10% (mm)	Install screws (M)	Hole spacing ±10%	Plate thickness (mm)
ZGT-150	50-150	4	120	80	90	12	100	5
ZGT-280	150-280	4	125	100	95	12	105	5
ZGT-450	280-450	4	130	110	105	12	110	5
ZGT-600	450-600	4	140	120	110	12	120	6
ZGT-750	600-750	4	160	140	110	12	140	6
ZGT-900	750-900	4	160	140	125	12	140	8
ZGT-1200	900-1200	4	190	160	125	14	170	8
ZGT-1800	1200-1800	4	190	160	145	14	170	10
ZGT-2500	1800-2500	4	200	170	145	14	180	10
ZGT-3500	2500-3500	4	210	180	160	14	190	12
ZGT-5000	3500-5000	4	210	180	165	14	190	14
ZGT-7000	5000-7000	6	260	230	165	14	240	16

Special-shaped shock absorbers can be customized according to customer needs
Note: Dimensions are measured manually and there may be errors. The actual size shall prevail.

ZD type damping spring shock absorber



The ZD type damping spring shock absorber offers a unique combination of low spring frequency and high rubber damping, effectively addressing resonance issues and high natural frequencies. Suitable for active, passive, and impact isolation, it operates in temperatures from -20°C to 80°C , with a natural frequency of 4.5Hz to 4.9Hz and a damping ratio of 0.065. Ideal for equipment like air conditioners, fans, compressors, and more, it's a versatile solution for various shock-absorption needs.

Applicable equipment: air conditioners, fans, compressors, cooling towers, refrigeration units, water pumps, transformers, and air energy systems.

Load range: 10–3500kg

Product Description

Model	Load (kg)	Upper circle diameter (mm)	Hole spacing (mm)	Base length (mm)	High (mm)	Mounting bolts
ZD-1	30–50	110	160	200	82	M12
ZD-2	50–80	110	160	200	83	M12
ZD-3	80–120	110	160	200	84	M12
ZD-4	120–160	110	160	200	85	M12
ZD-5	160–200	121	160	200	86	M12
ZD-6	200–260	121	160	200	87	M12
ZD-7	260–320	121	160	200	88	M12
ZD-8	320–360	121	160	200	88	M12
ZD-9	360–420	155	203	234	117	M12
ZD-10	420–480	155	203	234	117	M12
ZD-11	480–550	155	203	234	117	M12
ZD-12	550–630	155	203	234	117	M12
ZD-13	630–700	155	233	234	117	M16
ZD-14	700–800	180	233	270	126	M16
ZD-15	800–900	180	233	270	126	M16
ZD-16	900–1050	180	233	270	126	M16
ZD-17	1050–1200	180	233	270	126	M16
ZD-18	1200–1650	180	233	270	126	M16
ZD-19	1650–2200	250	305	355	150	M16
ZD-20	2200–2800	250	305	355	150	M16
ZD-21	2800–3500	250	305	355	150	M16

Note: Dimensions are measured manually and there may be errors. The actual size shall prevail.

Product Structure

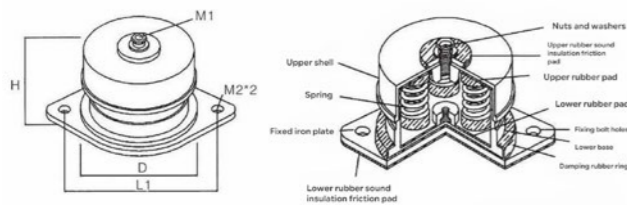

Installation diagram

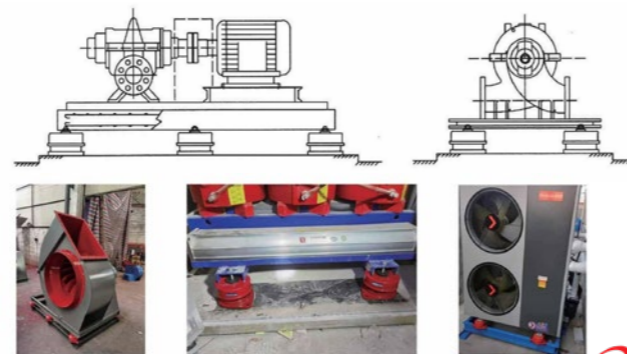

Support customization of special-shaped sizes and large loads.



Matrix transformer shock absorber



Matrix shock absorber, special shock absorber for transformer. The matrix shock absorber uses an anti-shock device inside, which is maintenance-free, has high safety performance, good fatigue resistance, easy installation, and saves time.

The diverse range of sizes cater to various transformers, ensuring easy installation and providing a high-quality, noise-free environment. Perfect for transformer rooms in both new constructions and renovations, it effectively reduces noise and vibrations while being easy to maintain. Meeting the transformer noise standard of 60dB, it utilizes high-performance shock absorbers to mitigate vibrations

caused by equipment operation. Additionally, soft connections are employed between the transformer and adjacent structures to further reduce noise. Specifically designed for dry-type transformers, these matrix shock absorbers serve as an ideal noise control solution.

Applicable equipment: Matrix shock absorbers are mainly used for shock absorption of dry-type transformers and are special shock absorbers for transformers.

Load range: 600–8000kg

Reference transformer model	Load range (Kg/piece)	Long (mm)	Width (mm)	High $\pm 10\%$ (mm)	Vertical stiffness (kg/mm)	Material
315KVA	720–880	900	300	150	32	Metal shell and spring set.
400KVA	1100–1280	900	300	150	48	
500KVA	1100–1280	1200	300	150	48	
630KVA	1280–1680	1200	300	150	64	
800KVA	1800–2100	1200	300	150	80	
1000KVA	2100–2350	1200	300	150	88	
1250KVA	2200–2450	1200	300	150	98	
1600KVA	2650–2950	1200	300	150	112	
2000KVA	2800–3200	1500	300	150	128	
2500KVA	3600–4200	1500	300	150	160	

Note: Dimensions are measured manually and there may be errors. The actual size shall prevail.

Installation diagram



Support customization of special-shaped sizes and large loads.



SD type rubber shock absorber



The SD type rubber isolation pad, with oil-resistant properties, is easily installed and used for seismic isolation and noise reduction in mechanical equipment. Available in three hardness options and a standard size, it can be cut and combined to suit various loads (Three rubber hardnesses: 40°, 60°, and 80°, The basic block size is 85mm*85mm.). Stacking pads in layers enhances isolation effectiveness, reducing natural frequency while maintaining load capacity.

Working temperature: -5~50°C
 Damping ratio: 0.098
 Natural frequency range: 5~18HZ

Product Description

Model	Specification (mm)	Area (cm ²)	Load (Kg)	Number of layers (mm)	Corresponding static deformation (mm)	Corresponding natural frequency (Hz)
	length*width*height					
SD61-1	85*85*20	72	144-230	1	2.5-4.0	13.2-10.6
SD62-1	85*85*44	72	144-230	2	5.0-8.0	9.3-7.5
SD63-1	85*85*68	72	144-230	3	7.5-12.0	7.6-6.1
SD64-1	85*85*92	72	144-230	4	10.0-16.0	6.6-5.3
SD61-2	170*85*20	145	220-474	1	2.5-4.0	13.2-10.6
SD62-2	170*85*44	145	220-474	2	5.0-8.0	9.3-7.5
SD63-2	170*85*68	145	220-474	3	7.5-12.0	7.6-6.1
SD64-2	170*85*92	145	220-474	4	10.0-16.0	6.6-5.3
SD61-4	170*170*20	290	456-970	1	2.5-4.0	13.2-10.6
SD62-4	170*170*46	290	456-970	2	5.0-8.0	9.3-7.5
SD63-4	170*170*72	290	456-970	3	7.5-12.0	7.6-6.1
SD64-4	170*170*98	290	456-970	4	10.0-16.0	6.6-5.3
SD61-6	255*170*20	433	934-1328	1	2.5-4.0	13.2-10.6
SD62-6	255*170*46	433	934-1328	2	5.0-8.0	9.3-7.5
SD63-6	255*170*72	433	934-1328	3	7.5-12.0	7.6-6.1
SD64-6	255*170*98	433	934-1328	4	10.0-16.0	6.6-5.3
SD61-8	340*170*20	578	1260-1940	1	2.5-4.0	13.2-10.6
SD62-8	340*170*46	578	1260-1940	2	5.0-8.0	9.3-7.5
SD63-8	340*170*72	578	1260-1940	3	7.5-12.0	7.6-6.1
SD64-8	340*170*98	578	1260-1940	4	10.0-16.0	6.6-5.3

Note: Dimensions are measured manually and there may be errors. The actual size shall prevail.

Product Structure

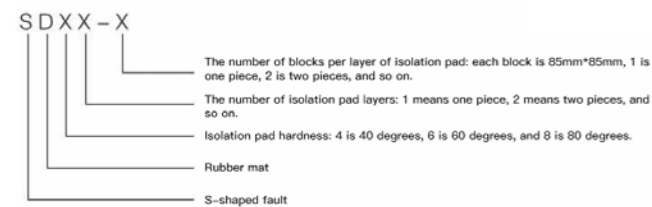

Installation diagram

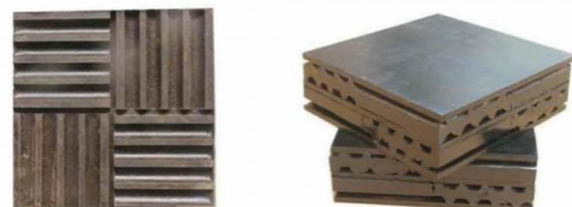

Support customization of special-shaped sizes and large loads.



JG type rubber shock absorber



JG type shock absorber is made of built-in shear steel plate, fixed parts and rubber body. The product is divided into four sizes and structures, each size has eight load-bearing specifications. The axial load is from 10-1280kg. The static deformation under the rated load is in the range of 3-12mm. The corresponding natural frequency is in the range of 9-16Hz. The damping ratio is greater than 0.05. This shock absorber has good isolation effect on rotation and reciprocating mechanical vibration above 1000r/min.

Applicable equipment: water pumps, fans, cooling towers, air compressors, diesel engines, chillers, etc.
 Load range: 10-1280Kg

Product Description

Model	Load (Kg)	High (mm)	Bottom diameter (mm)	Bottom hole diameter (mm)	Hole center distance (mm)	Mounting screws	Inner circle diameter (mm)	Bottom thickness (mm)	Product weight (kg)
Round JGF-1	10-80	45	100	10	80	M12	33	8	0.3
Round JGF-2	80-150	55	150	13	130	M14	80	10	0.8
Round JGF-3	150-400	85	200	13	170	M16	122	13	1.8
Round JGF-4	300-600	110	300	13	267	M20	163	15	5.1
Round JGF-5	600-1000	115	300	13	267	M20	157	16	5.2
Square JGF-1	10-80	50	100	10	77	M12	78	10	0.3
Square JGF-2	80-150	61	150	13	100	M12	100	10	0.8
Square JGF-3	150-400	90	200	14	145	M16	115	11	2
Square JGF-4	400-1280	105	200	16	160	M20	146	15	4.5
Round JG-1	10-100	43	100			M12	68	10	0.3 0.4kg hooded
Round JG-2	100-200	57	145			M12	97	10	0.7 0.7kg hooded
Round JG-3	200-400	90	200			M16	145	10	1.6 1.8kg hooded
Round JG-4	400-1000	135	285			M20	223	18	5.8 6.2kg hooded

Product Structure

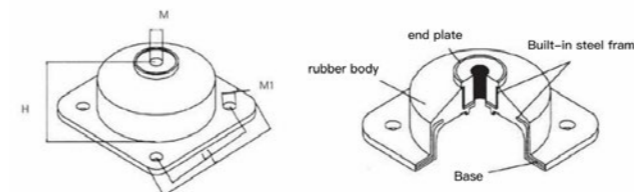

Installation diagram



Support customization of special-shaped sizes and large loads.



JGF type rubber shock absorber (round)



JGF type shock absorber is made of built-in shear steel plate, fixed parts and rubber body. The product is divided into four sizes and structures, each size has eight load-bearing specifications. The axial load is from 10-1280kg. The static deformation under the rated load is in the range of 3-12mm. The corresponding natural frequency is in the range of 9-16Hz. The damping ratio is greater than 0.05. This shock absorber has good isolation effect on rotation and reciprocating mechanical vibration above 1000r/min.

Applicable equipment: water pumps, fans, cooling towers, air compressors, diesel engines, chillers, etc. Load range: 10-1280Kg

Product Description

Model	Load (Kg)	High (mm)	Bottom diameter (mm)	Bottom hole diameter (mm)	Hole center distance (mm)	Mounting screws	Inner circle diameter (mm)	Bottom thickness (mm)	Product weight (kg)
Round JGF-1	10-80	45	100	10	80	M12	33	8	0.3
Round JGF-2	80-150	55	150	13	130	M14	80	10	0.8
Round JGF-3	150-400	85	200	13	170	M16	122	13	1.8
Round JGF-4	300-600	110	300	13	267	M20	163	15	5.1
Round JGF-5	600-1000	115	300	13	267	M20	157	16	5.2
Square JGF-1	10-80	50	100	10	77	M12	78	10	0.3
Square JGF-2	80-150	61	150	13	100	M12	100	10	0.8
Square JGF-3	150-400	90	200	14	145	M16	115	11	2
Square JGF-4	400-1280	105	200	16	160	M20	146	15	4.5
Round JG-1	10-100	43	100			M12	68	10	0.3
Round JG-2	100-200	57	145			M12	97	10	0.7
Round JG-3	200-400	90	200			M16	145	10	1.6
Round JG-4	400-1000	135	285			M20	223	18	5.8

Product Structure

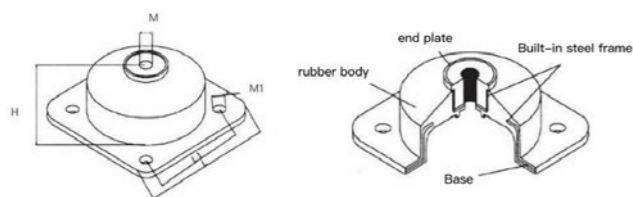

Installation diagram



Support customization of special-shaped sizes and large loads.



JGF type rubber shock absorber (square)



JGF type shock absorber is made of built-in shear steel plate, fixed parts and rubber body. The product is divided into four sizes and structures, each size has eight load-bearing specifications. The axial load is from 10-1280kg. The static deformation under the rated load is in the range of 3-12mm. The corresponding natural frequency is in the range of 9-16Hz. The damping ratio is greater than 0.05. This shock absorber has good isolation effect on rotation and reciprocating mechanical vibration above 1000r/min.

Applicable equipment: water pumps, fans, cooling towers, air compressors, diesel engines, chillers, etc. Load range: 10-1280Kg

Product Description

Model	Load (Kg)	High (mm)	Bottom diameter (mm)	Bottom hole diameter (mm)	Hole center distance (mm)	Mounting screws	Inner circle diameter (mm)	Bottom thickness (mm)	Product weight (kg)
Round JGF-1	10-80	45	100	10	80	M12	33	8	0.3
Round JGF-2	80-150	55	150	13	130	M14	80	10	0.8
Round JGF-3	150-400	85	200	13	170	M16	122	13	1.8
Round JGF-4	300-600	110	300	13	267	M20	163	15	5.1
Round JGF-5	600-1000	115	300	13	267	M20	157	16	5.2
Square JGF-1	10-80	50	100	10	77	M12	78	10	0.3
Square JGF-2	80-150	61	150	13	100	M12	100	10	0.8
Square JGF-3	150-400	90	200	14	145	M16	115	11	2
Square JGF-4	400-1280	105	200	16	160	M20	146	15	4.5
Round JG-1	10-100	43	100			M12	68	10	0.3
Round JG-2	100-200	57	145			M12	97	10	0.7
Round JG-3	200-400	90	200			M16	145	10	1.6
Round JG-4	400-1000	135	285			M20	223	18	5.8

Product Structure

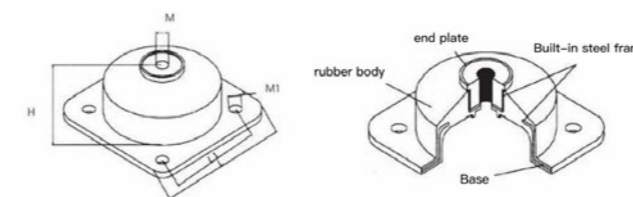

Installation diagram



Support customization of special-shaped sizes and large loads.



BE type rubber shock absorbing pad



BE series shock absorbers are mainly used for vibration isolation and noise reduction of ship generator sets, diesel generator sets, aerospace industry equipment and various power equipment.

1. The natural frequency of BE series shock absorbers under rated load is 8-10Hz.
2. The structure is simple, the installation is more convenient, and the use is safe and reliable. Compared with similar products, it has smaller dimensions under the same load and stiffness.
3. Suitable for various installation forms such as horizontal placement, inversion and side hanging.
4. The transverse stiffness is higher than the

longitudinal stiffness, the transverse stability is good when placed horizontally, and it has a limited protection device.

Applicable equipment: vibration isolation and noise reduction of water pumps, fans, cooling towers, air compressors, diesel engines, chillers, ship engines and other equipment.

Load range:10-400kg

Product Description

Model	M	L	L1	H	B	B1	N	D
BE-10	M8	70	54	40	36		2	Φ7
BE-15	M8	70	54	40	36		2	Φ7
BE-25	M8	70	54	40	40		2	Φ7
BE-40	M10	85	68	46	55		2	Φ9
BE-60	M12	100	80	50	65		2	Φ9
BE-85	M14	120	100	60	70		2	Φ11
BE-120	M16	140	112	60	85		2	Φ13
BE-160	M18	145	115	62	90		2	Φ13
BE-220	M22	150	120	70	105		2	Φ15
BE-300	M24	155	125	75	110	60	4	Φ15
BE-400	M27	175	140	80	120	65	4	Φ17

Product Structure

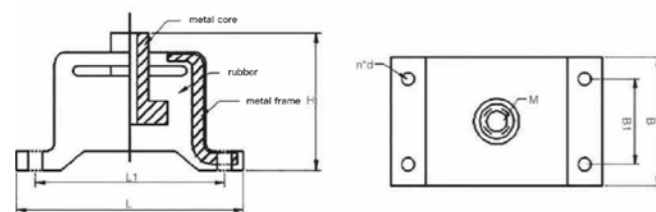

Installation diagram

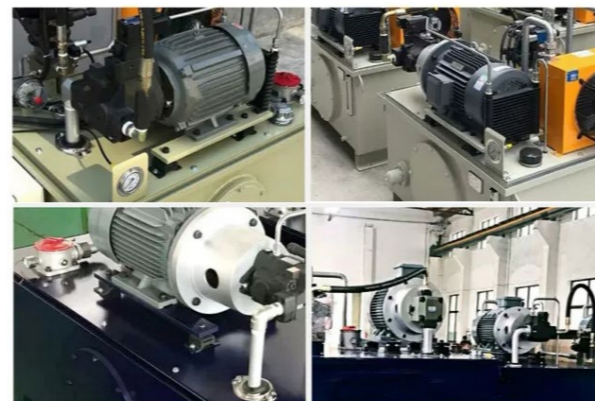

ZA type metal rubber shock absorber



ZA series shock absorbers are composed of upper and lower shells and rubber shock-absorbing layers. They are suitable for vibration and impact isolation of various types of marine, land and aviation mechanical equipment above 1500 rpm. Its natural frequency under rated load is 10HZ. The structure is simple, easy to install and update, and reliable to use. There are various installation methods, suitable for horizontal, inverted and side-mounted installation. The lateral stiffness is higher than the longitudinal height, and the lateral stability is better when placed flat.

Scope of application: Vibration and impact isolation of various types of marine, land and aviation machinery and equipment above 1500 rpm.

Product Description

Model	Long	Hole spacing	Width	High	Screw	Load bearing (kg)
ZA-110	100	85	70	35	12	70-200
ZA-135	135	110	83	38	12	150-250
ZA-150	152	120	100	42	16	200-350
ZA-175	178	143	108	43	16	300-550
ZA-190	190	158	122	52	16	400-900
ZA-218	219	181	150	57	16	750-1650
ZA-238	170	132	150	50	20	1100
ZA-268	190	150	180	66	20	2300

Note: Dimensions are measured manually and there may be errors. The actual size shall prevail.

Product Structure

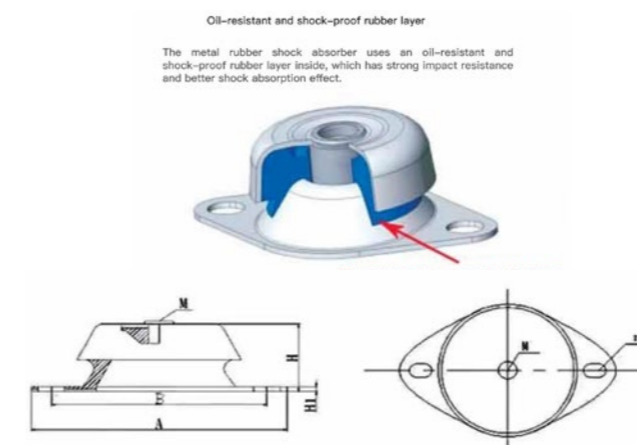

Installation diagram



Air conditioning shock absorber support



The air-conditioning shock-absorbing support is made of rubber body and fixed parts bonded together. Easy to install and has no effect on temperature differences. For outdoor units of air conditioners, air energy and small water pumps have good isolation effects.

Scope of application: air conditioner outdoor unit, air energy, small water pump.

Product Description

Model	L1	L2	W1	W2	H1	H2	H3	Aperture (mm)	Screw
5.5cm	110	49	47	38	55	22	15	10	M8
8cm	100	59	100	59	80	20	15	10	M10
12cm	119	55	119	55	120	24	25	12	M10
15cm	142	71	142	71	150	24	25	12	M10

Note: Dimensions are measured manually and there may be errors. The actual size shall prevail.

Product Structure

Installation diagram

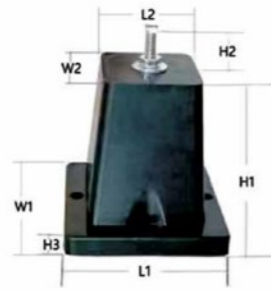
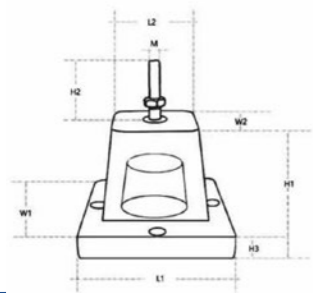

Rubber shock absorber pad



Rubber shock-absorbing pad is a type of shock-absorbing product made of rubber material, commonly used to reduce the propagation of vibration and noise. Rubber materials have good elasticity and shock absorption properties, which can effectively absorb the vibration energy generated by mechanical equipment or structures, reducing the impact of vibration on the surrounding environment and equipment.

ASD-A type air spring shock absorber



The low-frequency air spring shock absorber is an elastic element consisting of an air chamber, a rubber elastic diaphragm, and a support plate. An air spring shock absorber is a non-metallic spring that adds pressurized air to a flexible closed container and uses the restoring force of the air when compressed to provide elastic force to achieve shock isolation and buffering effects. The air spring shock absorber has variable stiffness Characteristics, it is easy to obtain lower natural frequency (2.6–53Hz), higher damping ratio (0.06–0.08), and the shock absorption efficiency can reach more than 95%. The ASD low-frequency air

spring shock absorber adopts a support design internally, which improves the safety of use.

Load range: 50–4000Kg

Damping ratio: 0.06–0.08

Natural frequency: 2.6HZ–5.3HZ

Applicable equipment: punch press, reciprocating air compressor, shearing machine, cutting machine, centrifuge, embroidery machine, rooftop air conditioning unit, elevator, etc.

Product Description

Model	Load range (kg)	Base plate	Hole spacing (mm)	High (mm)	Screws
ASD-A-0	0–100	100x100	76	72	M10
ASD-A-1	100–200	145x145	105	100	M12
ASD-A-2	200–400	175x175	135	102	M16
ASD-A-3	400–700	200x200	160	102	M16
ASD-A-4	700–900	230x230	190	102	M16
ASD-A-5	700–1200	250x250	200	102	M16
ASD-A-6	1200–1600	315x315	265	105	M16
ASD-A-7	1600–2000	360x360	305	105	M16

Note: Dimensions are measured manually and there may be errors. The actual size shall prevail.

Product Structure

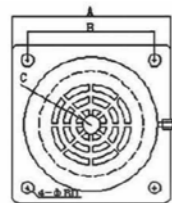

Installation diagram



Support customization of special-shaped sizes and large loads.

ASD-B type air spring shock absorber



Model	Long (kg)	Length and width (mm)	High ±10%
ASD-B-100	0–100	160x160	9.5
ASD-B-100	100–200	180x180	11.5
ASD-B-100	200–400	220x220	11.5
ASD-B-100	400–700	250x250	12.5
ASD-B-100	700–1200	300x300	13.5
ASD-B-100	1000–1200	400x400	13.5
ASD-B-100	1500–2500	450x450	15.5
ASD-B-100	2500–3500	500x500	15.5

Note: Dimensions are measured manually and there may be errors. The actual size shall prevail.

Product Description

The low-frequency air spring shock absorber is an elastic element consisting of an air chamber, a rubber elastic diaphragm, and a support plate. An air spring shock absorber is a non-metallic spring that adds pressurized air to a flexible closed container and uses the restoring force of the air when compressed to provide elastic force to achieve shock isolation and buffering effects. The air spring shock absorber has variable stiffness characteristics, it is easy to obtain a lower natural frequency (2.6–5.3Hz), a higher damping ratio (0.06–0.08), and the shock absorption efficiency can reach more than 95%. The ASD low-frequency air spring shock absorber adopts a support design internally, which improves the safety of use.

Applicable equipment: Suitable for punches, high-speed punches, air compressors, heavy-duty generators, air conditioning hosts, electronic production equipment, surface roughness meters, profile shape measuring instruments, microscopes, semiconductor inspection devices, optical experimental equipment, electronic experimental instruments, etc. Precision equipment and various types of industrial equipment, etc.

Load range: 0–4000kg

Product Structure

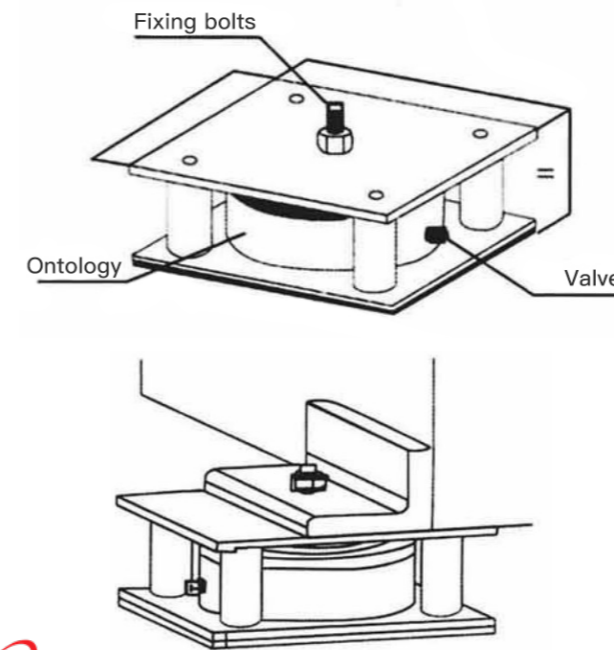

Installation diagram

The equipment is running upstairs and quiet downstairs (sound insulation rate is over 98%) Pneumatic anti-vibration device, designed with hydraulic damping cylinder. Suitable for eliminating impact vibration, low natural frequency value design, good anti-vibration effect.



Support customization of special-shaped sizes and large loads.

DT type pipe elastic bracket shock absorber

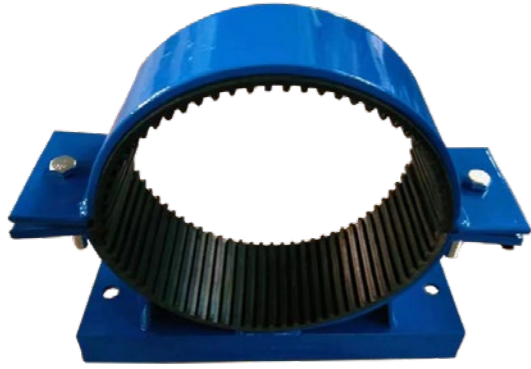

The DT type pipe elastic bracket shock absorber is made of an arc-shaped concave and convex rubber elastic pad and a partially pasted arc-shaped metal plate. It is usually used on pipelines equipped with elastically supported mechanical equipment to provide elastic support for the pipeline. It can also isolate the pipeline from the wall when it passes through the wall. It has a good isolation effect on the mechanical vibration transmitted by the pipeline and has a significant effect on reducing structural noise. function, thereby improving the environment and extending the service life of the equipment. This product allows normal operation at -10°C – 50°C

ambient temperature.

Applicable equipment: air conditioning, fire protection and other pipes.

Load range: 50–1000kg

Supports customization of special-shaped sizes and large loads.

Product Description

DT type pipe elastic bracket shock absorber (half bracket) size table

The way to	Load (kg)	Pipe outer diameter	Long base	Base width	Hole diameter	Steel plate thickness	Rubber thickness	Support steel plate thickness	Arc plate thickness	Center distance
DN65	50–130	73	140	80	12	5	8	3	3	110
DN80	50–130	89	160	80	12	5	8	3	6	130
DN100	70–130	108	180	100	14	6	8	3	6	150
DN125	70–130	133	200	100	14	6	8	3	6	170
DN150	70–130	168	220	100	14	6	8	3	6	190
DN200	90–220	219	250	100	14	8	8	4	6	220
DN250	90–220	273	300	100	14	8	8	4	6	270
DN300	110–270	325	350	100	14	10	8	4	6	330
DN350	110–270	355	400	100	14	10	8	4	6	370
DN400	140–350	406	450	100	14	10	8	4	6	420
DN450	140–350	478	50	100	14	12	8	4	8	470
DN500	80–450	530	550	100	14	12	8	5	8	520

Note: Dimensions are measured manually and there may be errors. The actual size shall prevail.

DT type pipe elastic bracket shock absorber (full bracket) dimension table

The way to	Load (kg)	Pipe outer diameter	Long base	Base width	Hole diameter	Steel plate thickness	Rubber thickness	Support steel plate thickness	Arc plate thickness	Center distance
DN65	50–130	73	200	80	12	5	8	3	3	170
DN80	50–130	89	210	80	12	5	8	3	3	180
DN100	70–130	108	240	100	14	8	8	3	6	210
DN125	70–130	133	260	100	14	8	8	3	6	230
DN150	70–130	168	300	100	14	8	8	3	6	270
DN200	90–220	219	350	100	14	8	8	4	6	320
DN250	90–220	273	400	100	14	10	8	4	6	370
DN300	110–270	325	450	100	14	10	8	4	6	420
DN350	110–270	355	480	100	14	10	8	4	6	450
DN400	140–350	406	540	100	14	12	8	4	6	510
DN450	140–350	478	610	100	14	12	8	4	8	580
DN500	145–350	530	660	100	14	14	8	5	8	630

Note: Dimensions are measured manually and there may be errors. The actual size shall prevail.

Product Structure

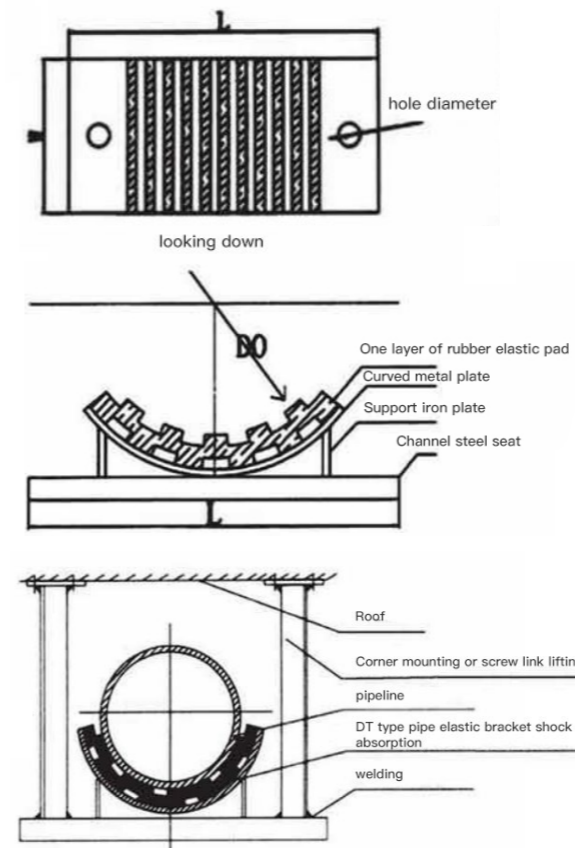

Installation diagram



XDD type pipe hanger



The XDD type pipe hanger is a pipe shock absorbing hanger shock absorber in which rubber and iron frames are bolted together. On the one hand, it can fix the pipe and has good isolation on the vibration and noise generated when the medium flows in the pipe. Shock isolation effect.
Scope of application: Suitable for various round pipes.

Product Description

Selection principles

- 1.Ensure damping efficiency above 80%, with a frequency ratio greater than 2.5.
- 2.External interfaces should be flexibly connected to prevent failure, with stiffness much lower than the system's total stiffness.
- 3.Calculate total mass (W) as Q1 multiplied by a dynamic load coefficient (P), plus Q2. P varies based on equipment size and disturbance frequency. Choose P between 1.1 to 1.4. Determine interference frequency (F) and trial shock absorber number (S). Calculate load per shock absorber (P=W/S) and select appropriate shock absorber from parameter table.
- 4.Vibration force (amplitude, speed, acceleration) should be below allowable values, typically with a maximum vibration speed (Vmax) of <10mm/s, though specific equipment may have different criteria.

Model	Box outer width-W (mm)	Length inside the box-L (mm)	Box height-H (mm)	Rubber pillar (mm)	Bottom width-W (mm)	Overall height-H (mm)	upper mounting holes
DN50	40	62	85	50*30	83	208	M12
DN65	40	63	84	50*30	105	223	M12
DN80	40	75	100	50*40	110	270	M12
DN100	40	81	109	60*60	190	309	M12
DN125	40	79	108	60*60	155	324	M12
DN150	40	80	108	60*60	175	360	M12
DN200	40	80	108	70*60	230	480	M12

Note: Dimensions are measured manually and there may be errors.
The actual size shall prevail.

Product Structure



Installation diagram



Support customization of special-shaped sizes and large loads.

Shock absorber base



The shock-absorbing pedestal is also called a shock-absorbing support, an inertia support, and an inertia support. It structurally increases the base size and weight of the equipment, reasonably distributes the center of gravity of the equipment, increases equipment stability, and reduces equipment vibration transmission.
Equipped with shock absorbers: ZD damping spring shock absorber/ZTE damping spring shock absorber/JA damping spring shock absorber/ZGT open damping spring shock absorber/ZGT closed damping spring shock absorber YDS damping spring shock absorber wait.

Application: DG steel structure shock-absorbing bearings are mainly used in air conditioning units, large mechanical equipment, fans, water pumps, fans, and water pumps.

Product Structure

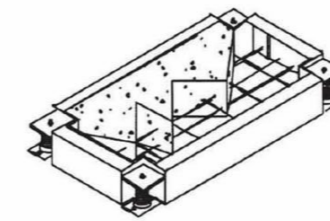

Built-in type (IBF-A type)

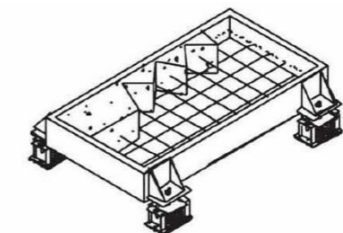

Side support type (IBF-B type)

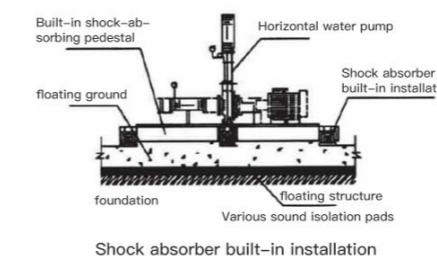

Shock absorber built-in installation

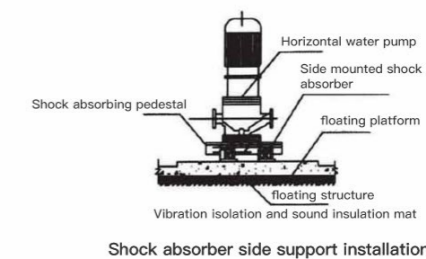

Shock absorber side support installation

Installation diagram

Shock absorbing pedestal equipped with ZD type shock absorber.

Type A (shock absorber) side support type

Type B (shock absorber) built-in

Type C (shock absorber) direct support type

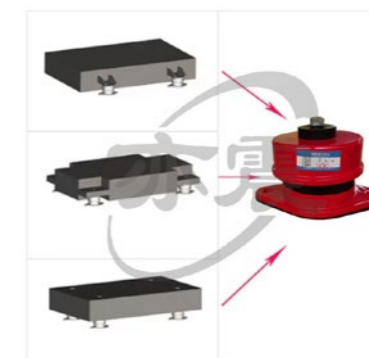

Support customization of special-shaped sizes and large loads.

Wall shock absorber



Model	Load (Kg)	A	C	H	M	D
ASE-30	5-30	50	50	100		8.5
ASE-50	30-50	50	50	100		11
ASE-100	50-100	60	60	120		13

Note: Dimensions are measured manually and there may be errors. The actual size shall prevail.

Product Description

The ceiling shock absorber is composed of a spring, a damping rubber layer, an outer frame and a boom. It can effectively isolate the transmission of vibration and sound, thus playing a good role in shock and sound isolation.

Scope of application of ceiling shock absorbers: sound insulation walls that isolate low-frequency vibrations, such as indoor active sound insulation structures in hotels, theaters, clubs, discos, KTVs, home theaters, bars, school piano rooms, recording studios, computer rooms, etc.

When building a high-sound-insulation composite wall, the keels and the wall are often rigidly connected with screws, resulting in a weakened blocking effect of the composite wall on low-frequency vibration sounds. The ceiling high sound insulation composite wall components are fixed with rubber and springs to basically eliminate the low-frequency vibration sound between the wall and the structure, thereby achieving the high sound insulation effect of the composite wall.

Key Features:

Essential for wall sound insulation, effectively blocking sound propagation.

Quick and easy installation, favored by acoustic installation companies.

Common specifications: 100*50*50mm

Product Structure



Installation diagram



Ceiling Installation:

Attach product to light steel keel and boom.
Install 2-3 products per square meter, adjusting boom length as needed.

Wall Installation:

Connect to light steel keel and boom with screws.
Use 1-2 shock absorbers per square meter, including U-shaped frame, damping rubber layer, and screw rod.

Effective vibration isolation, especially for venues with subwoofers.



Support customization of special-shaped sizes and large loads.

Light steel shock-absorbing keel



Model	Load (Kg)	A	C	H	M	D
ASE-30	5-30	50	50	100		8.5
ASE-50	30-50	50	50	100		11
ASE-100	50-100	60	60	120		13

Note: Dimensions are measured manually and there may be errors. The actual size shall prevail.

Product Description

The ceiling shock absorber is composed of a spring, a damping rubber layer, an outer frame and a boom. It can effectively isolate the transmission of vibration and sound, thus playing a good role in shock and sound isolation.

Scope of application of ceiling shock absorbers: sound insulation walls that isolate low-frequency vibrations, such as indoor active sound insulation structures in hotels, theaters, clubs, discos, KTVs, home theaters, bars, school piano rooms, recording studios, computer rooms, etc.

When building a high-sound-insulation composite wall, the keels and the wall are often rigidly connected with screws, resulting in a weakened blocking effect of the composite wall on low-frequency vibration sounds. The ceiling high sound insulation composite wall components are fixed with rubber and springs to basically eliminate the low-frequency vibration sound between the wall and the structure, thereby achieving the high sound insulation effect of the composite wall.

Key Features:

Essential for wall sound insulation, effectively blocking sound propagation.

Quick and easy installation, favored by acoustic installation companies.

Common specifications: 100*50*50mm

Product Structure



Installation diagram



Ceiling Installation:

Attach product to light steel keel and boom.
Install 2-3 products per square meter, adjusting boom length as needed.

Wall Installation:

Connect to light steel keel and boom with screws.
Use 1-2 shock absorbers per square meter, including U-shaped frame, damping rubber layer, and screw rod.

Effective vibration isolation, especially for venues with subwoofers.



Support customization of special-shaped sizes and large loads.

Floor spring shock absorber



Product name: Ground shock absorber

Product brand: Yichen

Product material: high quality steel plate and spring

Product performance: easy installation and strong practicality

Scope of application: used for house shock absorption, KTV bar sound insulation, cutting off structural vibration sound bridge.

Product Description

Model	Load (kg)	Overall dimensions (length, width and height)	Material	Weight
Ground vibration reduction (normal)	200	120X120X63		
Floor vibration reduction (with cork)	200	120X120X83		
Ground shock absorber	200	100*100*78	High-quality steel spring and rubber structure (rubber smell)	0.94KG/piece

Note: Dimensions are measured manually and there may be errors. The actual size shall prevail.

Product Structure



Support customization of special-shaped sizes and large loads.



Floating floor shock absorber



Model	Length (mm)	Width (mm)	Thickness (mm)
500*500*50mm	500	500	50
500*500*30mm	500	500	30

There may be differences between the parameters and the actual product.

Product Description

Material: rubber

Purpose: shock and noise reduction

Specifications: Customized on demand

Temperature resistance: -20C~120° C

Scope of application: used in industrial and mining enterprises, transportation departments

FRF type rubber vibration isolation and sound insulation mat is a new type of floating rubber product successfully developed based on the dynamic characteristics of rubber with superior vibration reduction and sound insulation effects. The structure of this floating vibration isolation pad is novel. There is a flat plate with convex grid lines on the top as an anti-slip surface. The bottom is an inverted frustum cone arranged in a square arrangement at equal intervals, and a hole is recessed in the middle of each inverted cone to form a The semicircular cavity increases the elasticity of the air cushion under working conditions, making the structure more reasonable in stress and better in performance. The basic shape is a standard square 500*500mm flat plate with concave and convex wedge-shaped grooves around the edges.

Floating vibration isolation and sound insulation panels are formed by vulcanization of natural rubber. There are 1 to 2 layers of nylon skeleton sandwiched in the middle of the panel. They are integrated by hot melt during the vulcanization process, so they are high in strength and durable.

The characteristic of the floating vibration isolation pad is that it is extremely convenient to install and construct, and can be combined with any shape of cross wedge. Before assembly, apply a layer of adhesive on each of the wedge-shaped concave and convex grooves, and then splice them into an overall floating vibration isolation and sound insulation board plane of any size and shape, and it has the characteristics of no leakage (especially cement mortar).

Product Structure



Unique design

The middle of each inverted cone is hollowed out to form a semicircular cavity, which increases flexibility during operation.

Support customization of special-shaped sizes and large loads.

